

Biology 1A Lab Exam I, Summer 2007

Bring a photo ID to the lab exam.

When: Thursday 7/26 from 12:40-2:05 in either 1 Pimentel or 2040 VLSB (see below). BE ON TIME. The exam will begin EXACTLY AT 12:40 PM (If you can not make the exam time, and only if you have arranged with Mike Meighan, then your exam will be scheduled earlier or later on Thursday).

Where: See below.

What: The 100-point lab will cover Labs 1-6. For more information see below and the backside. It will be about 65 points multiple choice and about 35 points short answer.

Level: Challenging! See the past exams in the exam reader.

Studying: Read the manual. For each lab be able to complete each objective. Be familiar with results and why they occurred. Look at your worksheets and pre-labs. Answers to these sheets are posted outside of 2084 VLSB. There are three samples of Lab Exam #1 in the Exam Reader (available at Replica Copy, 2040 Oxford).

Format: The exam will take the full 85 minutes and will begin at **12:40 PM sharp**. Do not be late. The exam will include multiple choice, short answers, essays, diagrams and fill-in-the-blanks. Be familiar with the equipment that you have used and why you performed certain procedures.

Reviews: Webcast reviews from last fall are available on-line from our webpage (towards the bottom) <http://mcb.berkeley.edu/courses/bio1a/Summer2007/>

Office Hours: Dr. Baxter M/W 2-3 T/Th 11-1/12, GSIs: M 10-11, 5:30-6:30, W 10-11, 3-4:30, 5:30-6:30. Mike W 12-12:30, 5-7 PM.

Be seated by 12:35 PM in your assigned room so that we can start handing out scantron forms.

ROOM ASSIGNMENTS: Know the location of your exam before the exam.

	GSI Name	Room #
101	Lew, Helen	2040 VLSB
102	An, Dahlia	1 Pimentel
103	Takata, Steve	1 Pimentel
104	Dhand, Rohini	1 Pimentel
105	Lew, Helen	2040 VLSB
106	An, Dahlia	1 Pimentel
107	Takata, Steve	1 Pimentel
108	Dhand, Rohini	1 Pimentel

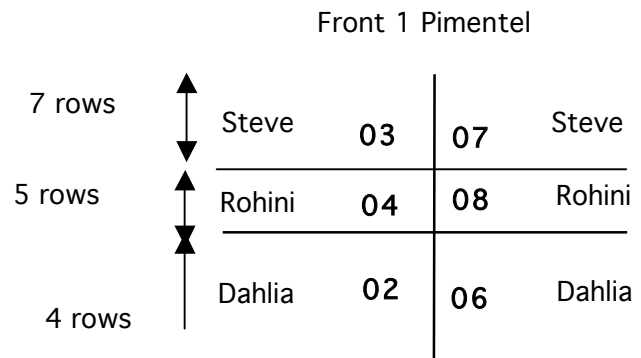
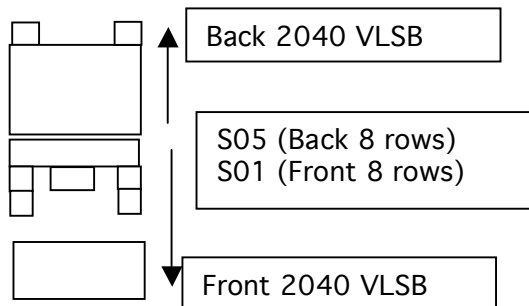

Seating is assigned by section #, within each room, by row. Seating is every THIRD seat (1,4,7, etc). Section numbers are abbreviated, e.g. 106 = 06.

CONTINUED ON THE BACKSIDE

SCANTRON FORM

Write in and bubble in your name, SID, and section #. The first 8 boxes of the ID # field are for your SID, the second two for the last 2 digits of your section #. See below.

SCANTRON FORM NO. F-4391 © SCANTRON CORPORATION 1992 ALL RIGHTS RESERVED. 04 M4 2102-999-54321

1	2	3	4	5	6	7	8	9
0	1	2	3	4	5	6	7	8
0	1	2	3	4	5	6	7	8
0	1	2	3	4	5	6	7	8
0	1	2	3	4	5	6	7	8
0	1	2	3	4	5	6	7	8
0	1	2	3	4	5	6	7	8
0	1	2	3	4	5	6	7	8
0	1	2	3	4	5	6	7	8
0	1	2	3	4	5	6	7	8

Write I.D. Number Here

Mark I.D. Number Here

SIDE 1
SID

NAME Last, First

TEST

DATE last 2 digits SECT #. DATE PERIOD GSI name

IMPORTANT
USE NO. 2 PENCIL ONLY
EXAMPLE: A B C D E
ERASE COMPLETELY TO CHANGE

MAKE SURE YOU KNOW HOW TO FILL OUT THE SCANTRON AND THAT YOU KNOW YOUR LAB SECTION NUMBER. MANY STUDENTS DID THIS INCORRECTLY ON EXAM 1.

General Sample Questions/Guideline. This list is only a **guide**.

- 1) Any objective listed in the lab manual. (Any safety questions will be very easy.)
- 2) Microscope Lab--Determine the size of field of view, calibrate a microscope, discuss what happens when you change magnification--depth of focus, amount of light, etc.
- 3) Cells & cell theory. Pro- vs. eukaryotes. Features of various kingdoms.
- 4) Monerans--cell morphology, cell wall structure and Gram-staining. Cyanobacteria--heterocyst vs. photosynthetic cell.
- 5) Discuss the locomotion and classification of protists.
- 6) Discuss various cell types and how they are arranged into functional tissue/organs/organisms.
- 7) Enzyme stuff: Kinetics, substrate concentration and varying enzyme concentration. How to affect enzyme activity. Why is it affected? Isozymes. Determine K_m . Why have different blanks? Role of DNS? How to measure the rate of a reaction--disappearance of substrate, appearance of product. How do you make dilutions? How do you determine enzyme activity of "spit"?
- 8) Photosynthesis--light dependent vs. -independent reactions. How to measure each? In various conditions? What are uncouplers? Inhibitors? How do they work? What is the role of an osmoticum? Explain osmotic pressure. What is the difference between a blank and a control? What is DCPIP? How is DCPIP functioning? What are pigments? What wavelengths are reflected/absorbed by a pigment of a given color? How could you isolate pigments and purify them? How could you make an absorption spectrum of a solution of pigments? How could you obtain purified pigments? How could you make an absorption spectrum of a purified sample?
- 9) What are restriction enzymes (RE)? Their role in the bacterium? How can we use them in experiments? What are the roles of buffers? When would you add them? What is meant by restriction digestion? What sizes of DNA would be produced by a given RE (given the RE sequence and the % base composition)?
- 10) How does electrophoresis work? What sort of predictions can you make about how various samples might migrate? How would you generate a standard curve and then apply the knowledge? What results would you get from specific digests, etc.? Generate a map of a piece of DNA from the restriction digestion. Is the DNA circular or linear? How could you clone in a given piece of DNA? What results would you predict if you transformed a certain type of bacteria with a given plasmid?
- 11) Be able to analyze crosses and make predictions. Be able to recognize recombinants and parental types. Use correct genetic notation for fruitflies.
- 12) What is a ligation reaction? What is transformation and what are some of the steps? Identify various types of colonies--why are they blue, white, etc. on AMP X-gal plates? What would happen if you used a given plasmid and were given different types of plates, etc. ?
- 13) Experimental design. What are controls? Which would you use in a given experiment? What data would you collect? Why? Advantage?
- 14) Define complementation. How could you determine the number of genes in a given pathway? How would you determine the order of steps of a given pathway?
- 15) Understand how sequencing reactions work. What is the difference between deoxy and dideoxy nucleotides?